



TENSION TECHNOLOGY
MARTIN



TENSION TECHNOLOGY MARTIN

In 2001 TENSION TECHNOLOGY MARTIN Srl was born, a company specializing in the study, design and construction of anchoring systems and installation equipment.

TTM produces single and multi-strand systems for bonded and unbonded post-tension, internal and external, composed of active and passive anchorages that can be installed with 0.6" strand of harmonic steel produced according to prEN 10138. Mono and multi-strand systems are generally used in prestressed structures such as bridges, viaducts and large buildings.

Years of activity in the sector, in addition to modern equipment and highly specialized personnel, have enabled the company to achieve a high level of know-how both on national and international markets.





PRODUCTION

From the first phase of the project a team of technicians and commercial managers collaborates to find the best solution that can satisfy the customer, our first purpose.

Our production ranges from single and multi strand anchorages, active and passive, internal and external, sleeves and couplers. We produce post-tension systems with bonded and unbonded strands for bridges, viaducts, floors, industrial floors, beams and tanks.

All system components are delivered to the construction site complete with the accessories needed for installation. The cables can be supplied cut to size, wrapped in rolls, and individually labelled.





GEOTECHNICAL GROUND ANCHORS

T.T.M. S.r.l. produces permanent and temporary ground anchors in compliance with the Ministerial Decree 14.01.2008 (and following edits) and Presidential Decree no. 12391 as of 22.12.2011 (guideline for the certification of the technical suitability for ground anchors for geotechnical applications). All the products also comply with the standard EN 1537-2013.

All the ground anchors can be installed with TTR-E and TTM anchorages and are made of wire strands in harmonic steel produced according to prEN 10138.

In order to guarantee a constant production over time and a quick service to customers, highly automatic plants were implemented to achieve a high level of production ensuring quality at the same time. The production of ground anchors is developed over four lines. The whole production system has a daily capacity of cutting of about 80.000 meters of strands by means of extremely high productiveness numerical control plants.

TEMPORARY GROUND ANCHORS

The Temporary ground anchors are usually used in the construction of bulkheads and diaphragms, where the type of ground does not have any particular geotechnical problems and where temporary ground anchors are needed. Normally the design life is not more than two years.

TPR-00A Series Single Corrosion Protection

- > Single strand encapsulated in Grease Filled Sheath
- > Fitted with Separation Pad
- > Jacketed with Smooth Duct over the Free Length

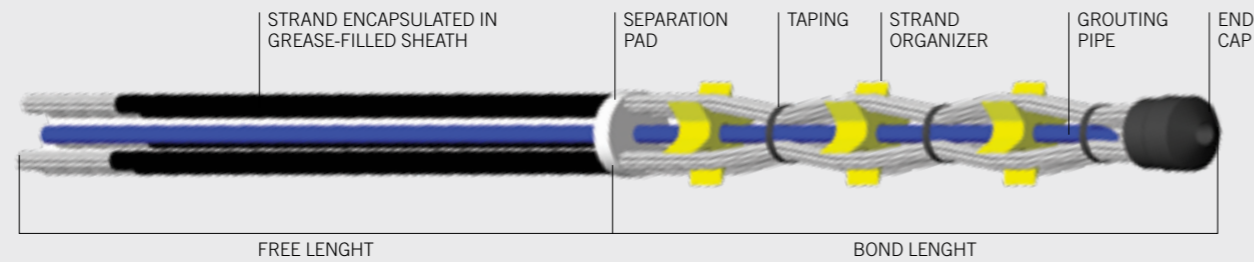

Other configurations available upon request.

TPR-04A Series Double Corrosion Protection

- > Single strand encapsulated in Grease Filled Sheath
- > Fitted with Separation Pad
- > Jacketed with Smooth Duct over the Free Length
- > Equipped with Internal Grouting Pipe in the Free Length 16/20 (I.G.U. Red)
- > Equipped with Post Grouting Manchette Pipe 27/34 (I.R.S)
- > On Demand, supplemental Grouting Pipe in the Bond Length 16/20 (I.G.U.)

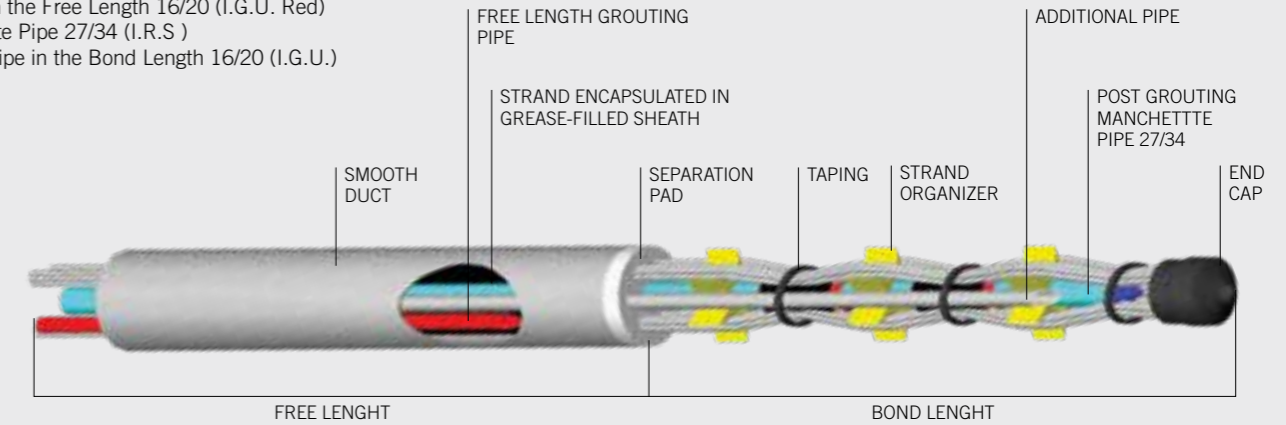

Other configurations available upon request.

TPR-01A Series Double Corrosion Protection

- > Single strand encapsulated in Grease Filled Sheath
- > Fitted with Separation Pad
- > Jacketed with Smooth Duct over the Free Length
- > Equipped with Grouting Pipe in the Bond Length 16/20 (I.G.U. Blue)
- > Equipped with Internal Grouting Pipe in the Free Length 16/20 (I.G.U. Red)

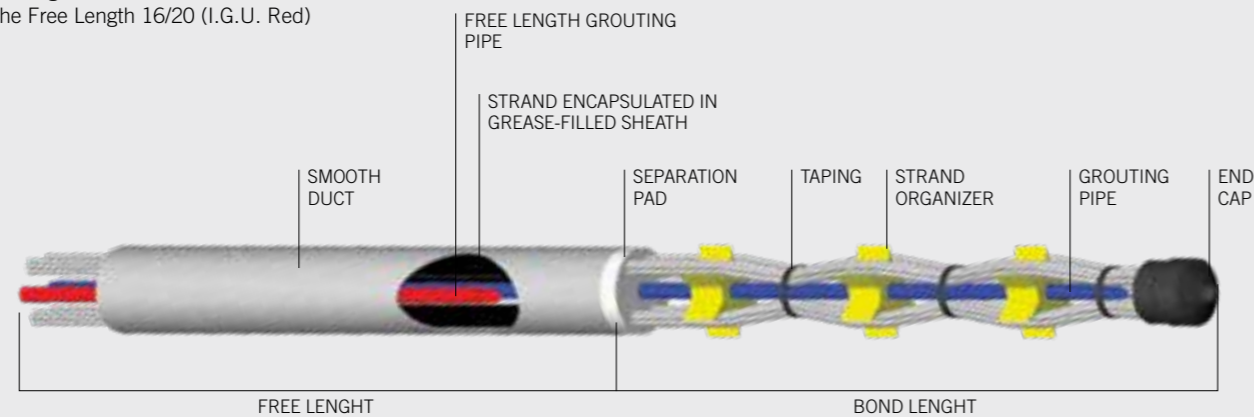

Other configurations available upon request.

TPR-04C Series Single Corrosion Protection

- > Single strand encapsulated in Grease Filled Sheath
- > Fitted with Separation Pad
- > Equipped with Post Grouting Manchette pipe 27/34 (I.R.S)
- > On Demand, supplemental Grouting Pipe in the Bond Length 16/20 (I.G.U.)

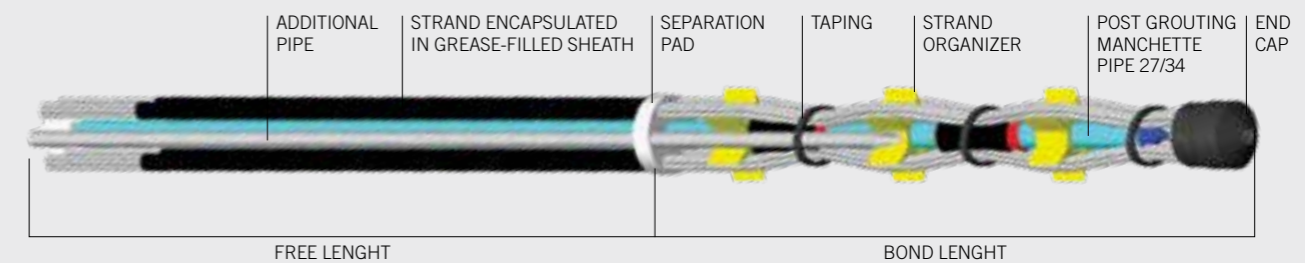

Other configurations available upon request.

PERMANENT GROUND ANCHORS

The Permanent ground anchors are defined as those which are to have a design life of more than two years. The minimum corrosion protection surrounding the tendon(s) of the anchor shall be a single continuous layer of corrosion preventive material which does not degrade during the design life of the anchor.

TPE-02A Series

Double Corrosion Protection

- > Single strand encapsulated in Grease Filled Sheath
- > Fitted with Single Strand Separation Pads
- > Jacketed with Corrugated Duct over the Entire Anchor Length
- > Equipped with External Grouting Pipe in the Bond Length 16/20 (I.G.U. Blue)
- > Equipped with Internal Grouting Pipe in the Bond Length 16/20 (I.G.U. Gray)
- > Fitted with External Centralizers (Two-Piece Snap-Fit Bow Centralizer)

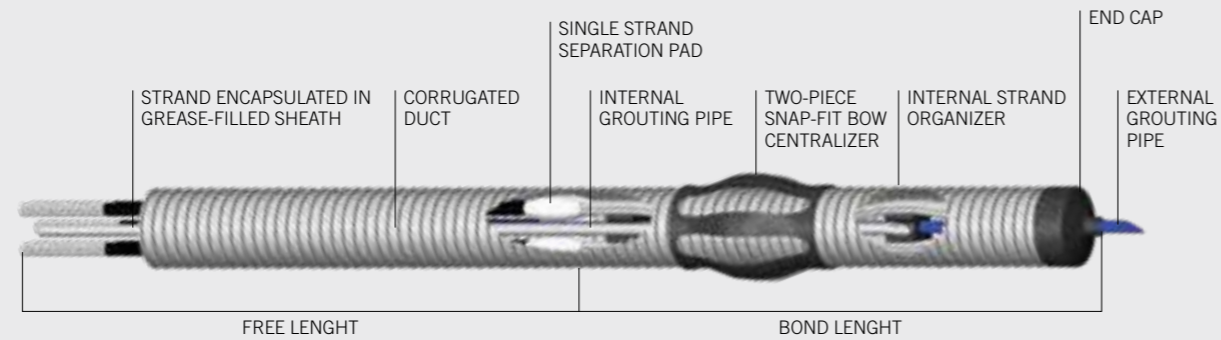

Other configurations available upon request.

TPE-08A Series

Double Corrosion Protection

- > Single strand encapsulated in Grease Filled Sheath
- > Fitted with Single Strand Separation Pads
- > Jacketed with Corrugated Duct over the Entire Anchor Length
- > Equipped with External Grouting Pipe in the Bond Length 16/20 (I.G.U. Blue)
- > Equipped with Internal Grouting Pipe in the Bond Length 16/20 (I.G.U. Gray)
- > Fitted with External Centralizers (Two-Piece Snap-Fit Bow Centralizer)
- > Equipped with Post Grouting Manchette Pipe 15/21 (I.R. Grouting)

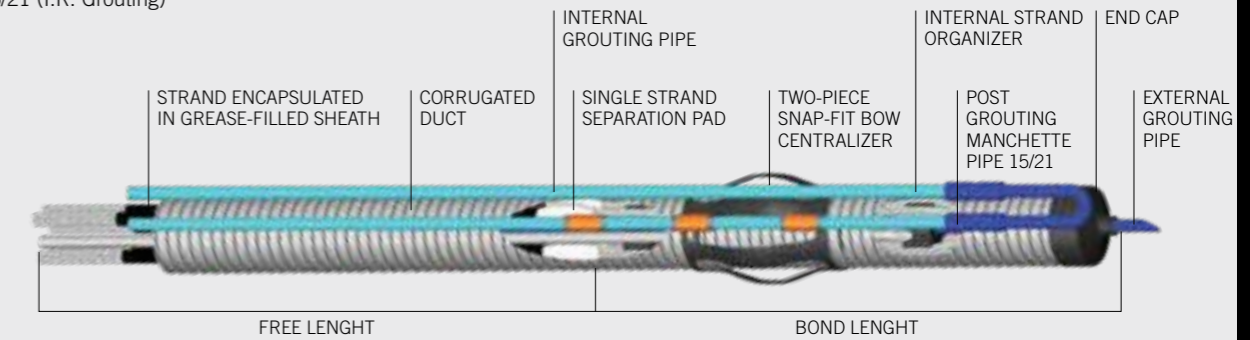

Other configurations available upon request.

TPE-02SPA Series

Double Corrosion Protection

- > Single strand encapsulated in Grease Filled Sheath
- > Fitted with Single Strand Separation Pads
- > Jacketed with Corrugated Duct over the Entire Anchor Length
- > Equipped with External Grouting Pipe in the Bond Length 16/20 (I.G.U. Blue)
- > Equipped with Internal Grouting Pipe in the Bond Length 16/20 (I.G.U. Gray)
- > Fitted with External Centralizers (Two-Piece Snap-Fit Bow Centralizer)
- > Equipped with Post Grouting Manchette Pipe 27/34 (I.R.S)

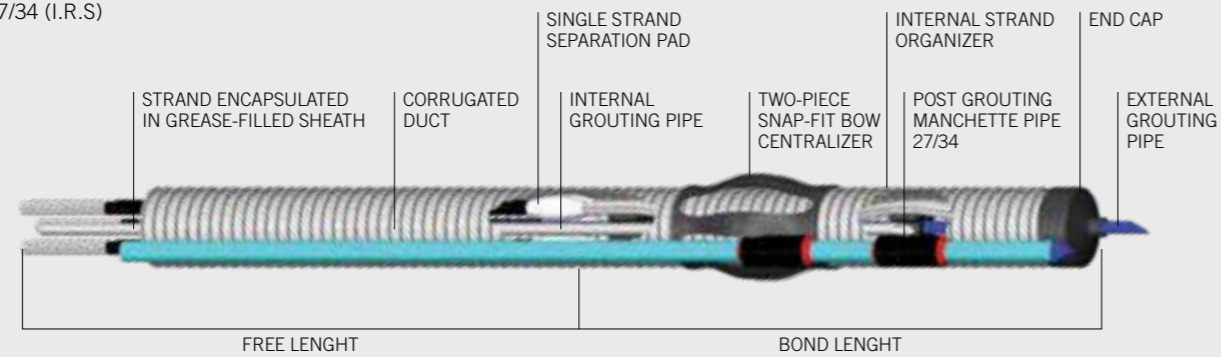

Other configurations available upon request.

TPE-08A Series

Double Corrosion Protection

- > Single strand encapsulated in Grease Filled Sheath
- > Fitted with Single Strand Separation Pads
- > Jacketed with Corrugated Duct over the Entire Anchor Length
- > Equipped with External Grouting Pipe in the Bond Length 16/20 (I.G.U. Blue)
- > Equipped with Internal Grouting Pipe in the Bond Length 16/20 (I.G.U. Gray)
- > Fitted with External Centralizers (Two-Piece Snap-Fit Bow Centralizer)
- > Equipped with Post Grouting Manchette Pipe 15/21 (I.R. Grouting)

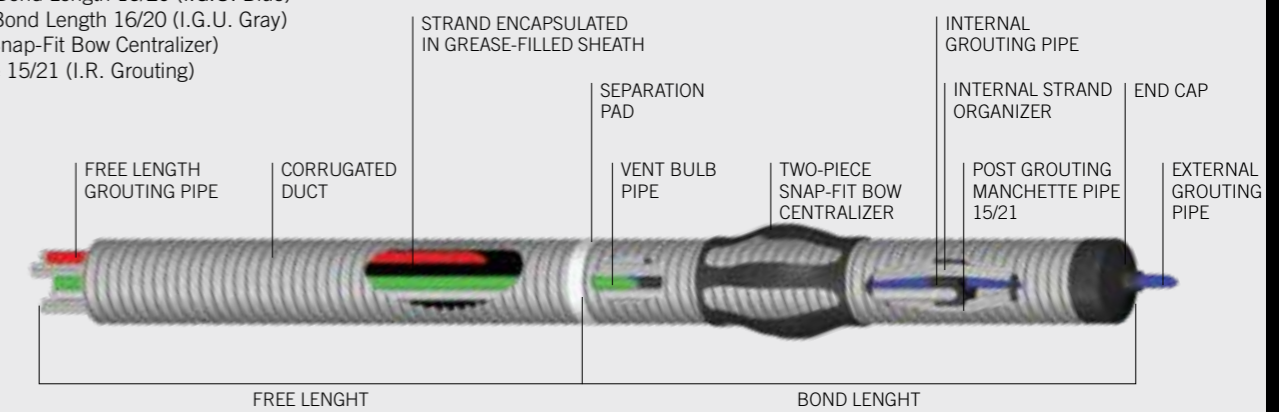

Other configurations available upon request.

PERMANENT GROUND ANCHORS

TPE-02SPB Series

Double Corrosion Protection

- > Single strand encapsulated in Grease Filled Sheath
- > Fitted with Separation Pad
- > Jacketed with Corrugated Duct over the Entire Anchor Length
- > Equipped with External Grouting Pipe in the Bond Length 16/20 (I.G.U. Blue)
- > Equipped with Internal Grouting Pipe in the Bond Length 16/20 (I.G.U. Gray)
- > Equipped with Internal Grouting Pipe in the Free Length 16/20 (I.G.U. Red)
- > Equipped with Vent Pipe in the Bond Length (Green)
- > Fitted with External Centralizers (Two-Piece Snap-Fit Bow Centralizer)
- > Equipped with Post Grouting Manchette Pipe 27/34 (I.R.S)

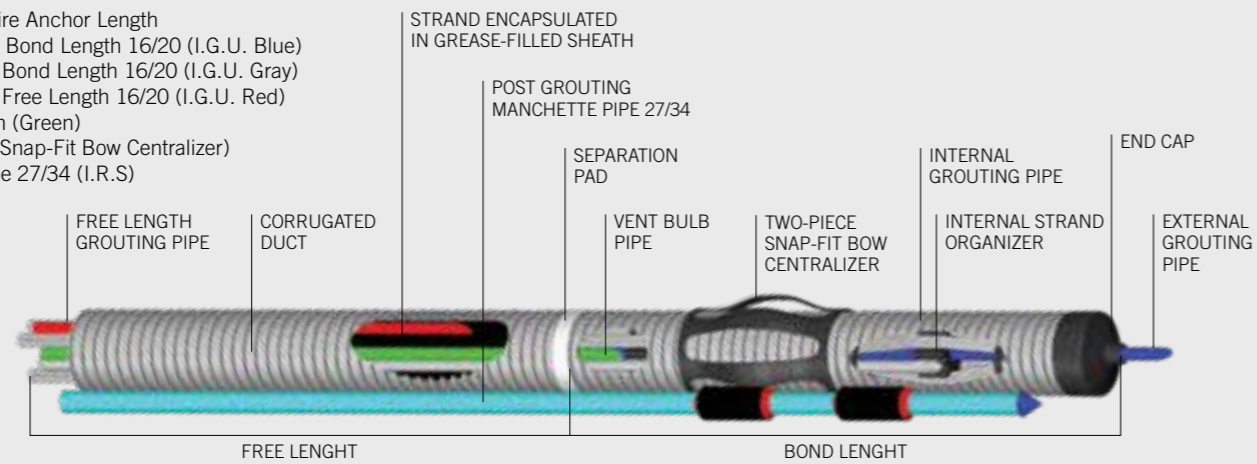

Other configurations available upon request.

TPH5_27_34 Series

Double Corrosion Protection

- > Single strand encapsulated in Grease Filled Sheath
- > Fitted with Separation Pad
- > Jacketed with Corrugated Duct over the Bulb Length and Smooth Duct over the Free Length
- > Equipped with External Grouting Pipe in the Bond Length 16/20 (I.G.U. Blue)
- > Equipped with Internal Grouting Pipe in the Bond Length 16/20 (I.G.U. Gray)
- > Equipped with Internal Grouting Pipe in the Free Length 16/20 (I.G.U. Red)
- > Equipped with Vent Pipe in the Bond Length (Green)
- > Fitted with External Centralizers (Two-Piece Snap-Fit Bow Centralizer)
- > Equipped with Post grouting manchette pipe 27/34 (I.R.S. Grouting)

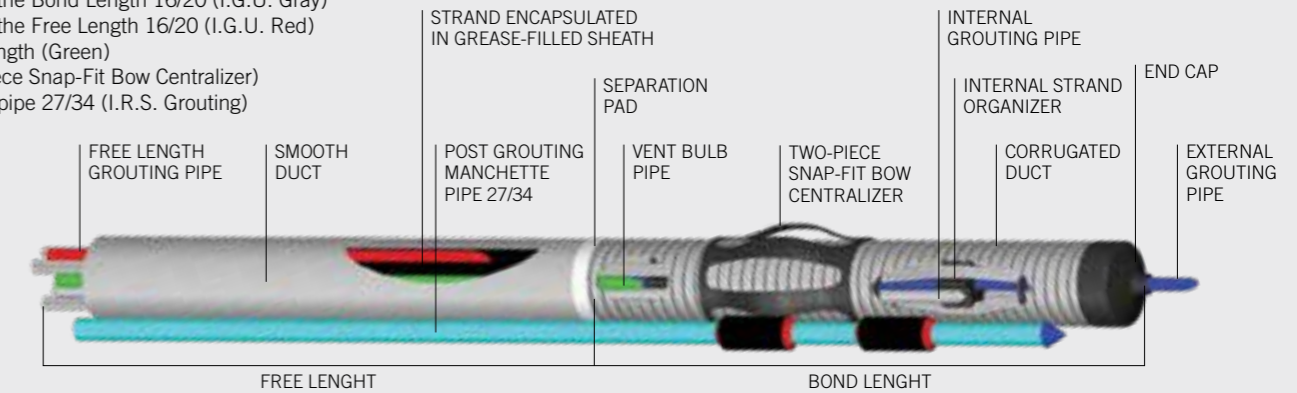

Other configurations available upon request.

TPH5 Series

Double Corrosion Protection

- > Single strand encapsulated in Grease Filled Sheath
- > Fitted with Separation Pad
- > Jacketed with Corrugated Duct over the Bulb Length and Smooth Duct over the Free Length
- > Equipped with External Grouting Pipe in the Bond Length 16/20 (I.G.U. Blue)
- > Equipped with Internal Grouting Pipe in the Bond Length 16/20 (I.G.U. Gray)
- > Equipped with Internal Grouting Pipe in the Free Length 16/20 (I.G.U. Red)
- > Equipped with Vent Pipe in the Bond Length (Green)
- > Fitted with External Centralizers (Two-Piece Snap-Fit Bow Centralizer)

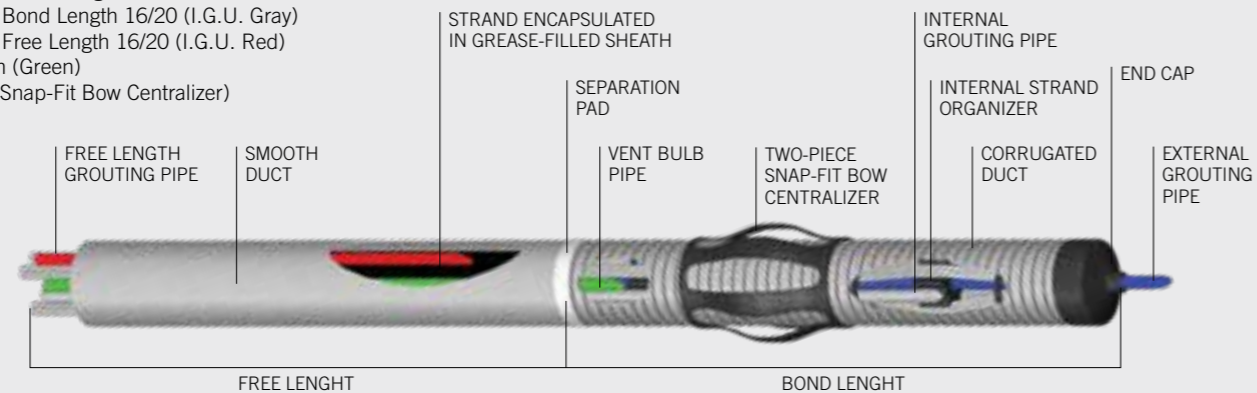

Other configurations available upon request.



ANCHOR HEAD TTR-E

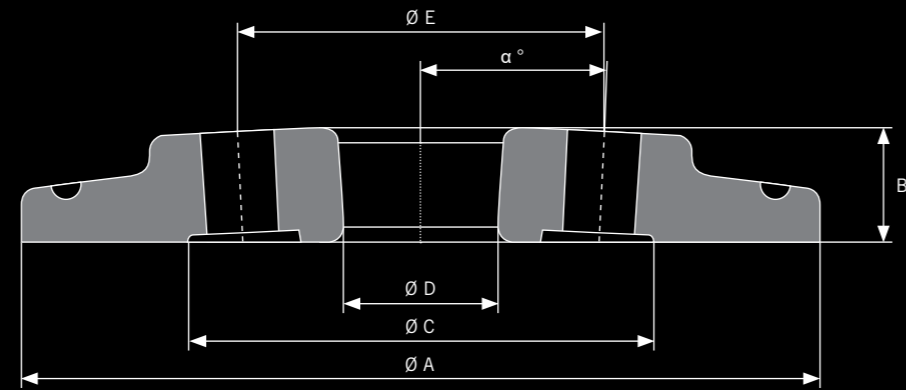

Type	A	B	C	D	E	α
2TTR-E	215	31	124	41	N. 2 holes $\varnothing 98$	3°
3TTR-E	215	31	124	41	N. 3 holes $\varnothing 98$	3°
4TTR-E	215	31	124	41	N. 4 holes $\varnothing 98$	3°
5TTR-E	240	37.5	145	41	N. 5 holes $\varnothing 120$	3°
6TTR-E	280	37.5	168	41	N. 6 holes $\varnothing 143$	3°
7TTR-E	300	37.5	194	41	N. 7 holes $\varnothing 169$	3°
8TTR-E	310	37.5	215	41	N. 8 holes $\varnothing 190$	3°

Dimensions in mm.

ANCHOR HEAD TTM / TTM-F

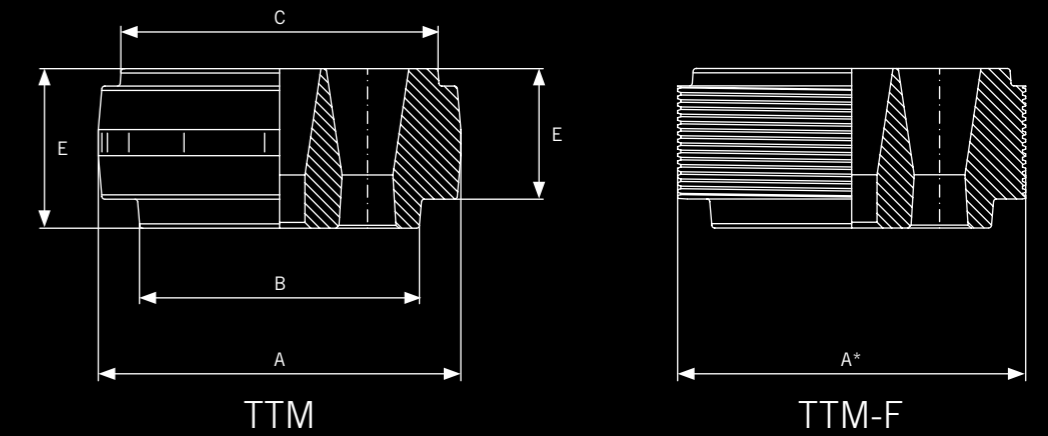

Type *	4M15 4M15-F	7M15 7M15-F	9M15 9M15-F	12M15 12M15-F	15M15 15M15-F
A	105	125	146	160	176
A*	103	123	143	158	173
B	80	98	118	134	146
C	95	110	130	145	158
D	45	45	45	45	45
E	53	55	58	63	63

Dimensions in mm.

*Others configurations are available. Please contact us for any information.



POST-TENSION SYSTEMS MULTISTRAND/MONOSTRAND ANCHORAGES

T.T.M. S.r.l. proposes to the construction and design of the various system solutions for post tension, bridges/viaducts, tanks and slabs.

All Bonded and Unbonded systems are produced in compliance with the guideline ETAG013, guaranteed over time and to ensure safe use in prestressed concrete structural elements and are in accordance with ETA.

The anchorages are tested and qualified to provide high fatigue resistance and durability.

The production of post tension anchors protected against corrosion is one of the main products offered today to structural engineering. These solutions are designed to offer high protection anchors over time, ensuring it by infiltrations or corrosive environments.

The system includes the use of the strand 7-wire in three types, Normal, Super and Compact.

The use of the strand T15C (Compact) with diameter and section respectively of 15.2 mm and 165 mm², allows to reduce the dimensions, by applying anchorages of smaller dimensions thus also reducing the size of the tensioning jacks.

The availability of steel strand is guaranteed by the ability of the Group, with two manufacturing facilities with an annual capacity of 150,000 tons.





PRODUCTION

From the first phase of the project a team of technicians and commercial managers collaborates to find the best solution that can satisfy the customer, our first purpose.

Our production ranges from single and multi strand anchorages, active and passive, internal and external, sleeves and couplers. We produce post-tension systems with bonded and unbonded strands for bridges, viaducts, floors, industrial floors, beams and tanks.

All system components are delivered to the construction site complete with the accessories needed for installation. The cables can be supplied cut to size, wrapped in rolls, and individually labelled.



Anchorage	Type	Multistrand
M	Active anchorage	Internal post-tensioning
D	Passive anchorage	Internal post-tensioning



Anchorage	Type	Multistrand
ME	Active anchorage	Replaceable external post-tensioning
MER	Active anchorage	Replaceable and restressable external post-tensioning
MEM	Active anchorage	Not-replaceable external post-tensioning
DEM	Passive anchorage	Not-replaceable external post-tensioning



Anchorage	Type	Monostrand
E	Active anchorage	Internal post-tensioning - slabs
ED	Passive anchorage	Internal post-tensioning - slabs
GX	Coupler	Internal post-tensioning - slabs



Anchorage	Type	Slab - flooring
N	Active anchorage	Internal post-tensioning - slabs
ND	Passive anchorage	Internal post-tensioning - slabs



Anchorage	Type	Multistrand
G	Coupler	Internal post-tensioning



D PASSIVE MULTISTRAND ANCHORAGES

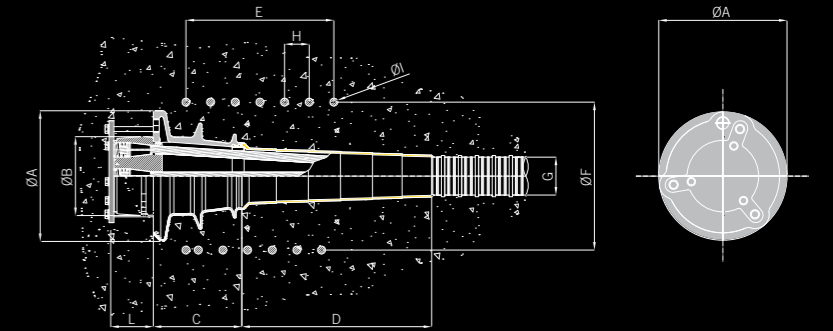

Type D	Strands	A [mm]	B [mm]	C [mm]	D [mm]	E [mm]	F [mm]	G [mm]	H [mm]	I [mm]	L [mm]
35MPa	4	160	105	103	300	205	180	45/50	45	12	90
	7	200	125	133	340	270	240	62/67	45	12	90
	9	235	146	163	380	270	300	72/77	45	14	90
	12	265	160	180	385	350	350	80/85	50	16	90
	15	290	176	197	405	450	410	85/90	50	16	90
	19	320	200	215	430	450	440	95/104	50	16	106
	22	355	230	260	430	425	480	100/109	50	18	111
45MPa	4	160	105	103	300	180	170	45/50	45	12	90
	7	200	125	133	340	250	220	62/67	45	12	90
	9	235	146	163	380	250	250	72/77	45	14	90
	12	265	160	180	385	300	300	80/85	50	16	90
	15	290	176	197	405	350	355	85/90	50	16	90
	19	320	200	215	430	425	400	95/104	50	16	106
	22	355	230	260	430	425	420	100/109	50	18	111
27	380	250	277	470	400	460	110/119	50	18	120	



M ACTIVE MULTISTRAND ANCHORAGES

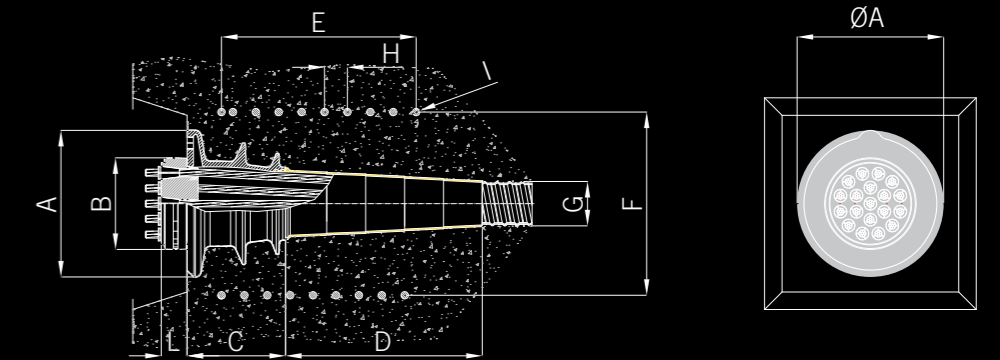
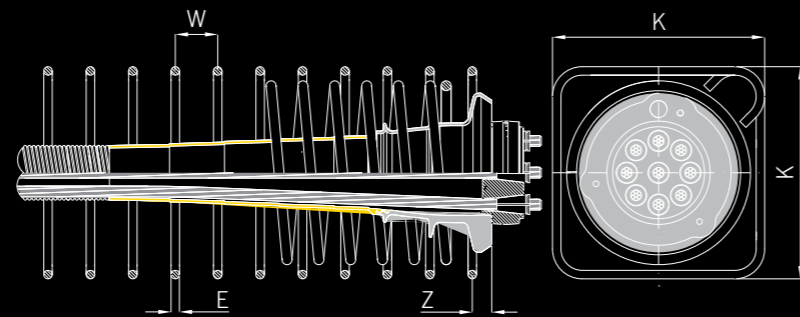

SPIRRAL

STIRRUP

Type M	Strands	A [mm]	B [mm]	C [mm]	D [mm]	Y [mm]	N.spire	E [mm]	K [mm]	W [mm]	Z [mm]	N.stirrup
35MPa	4	12	180	202,5	45	40	5	10	230	60	15	8
	7	12	240	270	45	50	7	12	315	60	20	11
	9	14	300	270	45	65	7	12	350	60	27,5	12
	12	16	350	350	50	65	7	12	410	60	27,5	14
	15	16	410	400	50	70	9	12	460	60	27,5	15
	19	16	440	450	50	75	9	12	525	60	27,5	18
	22	18	480	450	50	80	9	12	565	60	27,5	19
45MPa	4	12	170	180	45	40	4	10	210	60	15	8
	7	12	220	247,5	45	50	6	12	275	60	20	10
	9	14	246	247,5	45	65	6	12	300	60	27,5	11
	12	16	300	300	50	65	6	12	360	60	27,5	12
	15	16	354	350	50	70	8	12	410	60	27,5	14
	19	16	400	425	50	75	8	12	465	60	27,5	16
	22	18	420	425	50	80	8	12	500	60	27,5	17
27	18	460	400	50	80	8	12	560	60	27,5	19	

Type M	Strands	A [mm]	B [mm]	C [mm]	D [mm]	E [mm]	F [mm]	G [mm]	H [mm]	I [mm]	L [mm]
35MPa	4	160	105	103	300	205	180	45/50	45	12	45
	7	200	125	133	340	270	240	62/67	45	12	45
	9	235	146	163	380	270	300	72/77	45	14	45
	12	265	160	180	385	350	350	80/85	50	16	45
	15	290	176	197	405	450	410	85/90	50	16	45
	19	320	200	215	430	450	440	95/104	50	16	56
	22	355	230	260	430	425	480	100/109	50	18	61
45MPa	4	160	105	103	300	180	170	45/50	45	12	45
	7	200	125	133	340	250	220	62/67	45	12	45
	9	235	146	163	380	250	250	72/77	45	14	45
	12	265	160	180	385	300	300	80/85	50	16	45
	15	290	176	197	405	350	355	85/90	50	16	45
	19	320	200	215	430	425	400	95/104	50	16	56
	22	355	230	260	430	425	420	100/109	50	18	61
27	380	250	277	470	400	460	110/119	50	18	70	

EXTERNAL POST-TENSIONING ME ANCHORAGES

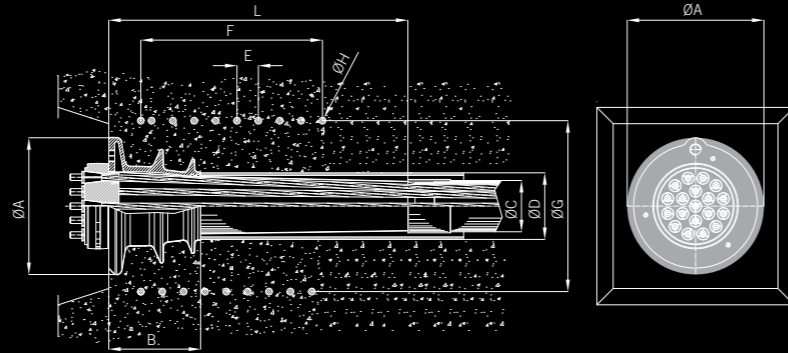

Type ME	Strands	A [mm]	B [mm]	C [mm]	D [mm]	E [mm]	F [mm]	G [mm]	H [mm]	I [mm]	L [mm]
35MPa	4	160	103	63	135	45	205	180	12	310	90
	7	200	133	75	160	45	270	240	45	360	90
	9	235	163	90	177	45	270	300	45	430	90
	12	265	180	110	195	50	350	350	50	450	90
	15	290	197	110	210	50	450	410	50	520	90
	19	320	215	125	245	50	450	440	50	645	106
	22	355	260	125	265	50	425	480	50	690	111
45MPa	27	380	277	140	295	60	480	530	50	745	120
	4	160	103	63	135	45	180	170	45	310	90
	7	200	133	75	160	45	250	220	45	360	90
	9	235	163	90	177	45	250	250	45	430	90
	12	265	180	110	195	50	300	300	50	450	90
	15	290	197	110	210	50	350	355	50	520	90
	19	320	215	125	245	50	425	400	50	645	106
	22	355	260	125	265	50	425	420	50	690	111
	27	380	277	140	295	50	400	460	60	745	120

G COUPLERS

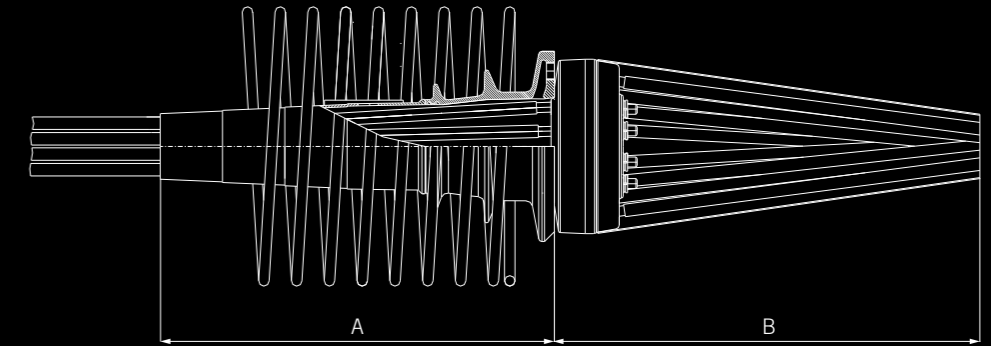

Strand	4	7	9	12	15	19	22	27
A [mm]	403	473	543	565	602	645	690	747
B [mm]	449	477	528	549	604	654	814	864

DISTANCES FROM THE EDGES

Strands	fcmj 35 MPa		fcmj 45 MPa	
	A [mm]	B [mm]	A [mm]	B [mm]
4	130	250	120	230
7	175	335	155	295
9	190	370	165	320
12	220	430	195	380
15	245	480	220	430
19	280	545	250	485
22	300	585	265	520
27	330	650	295	580

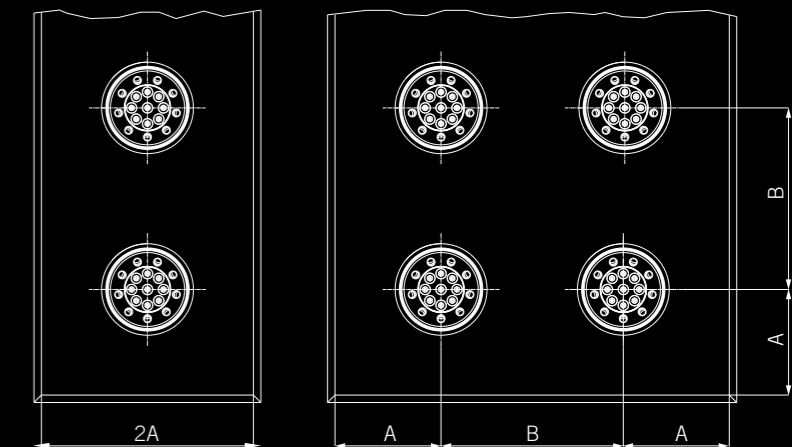

MONOSTRAND ANCHORAGES

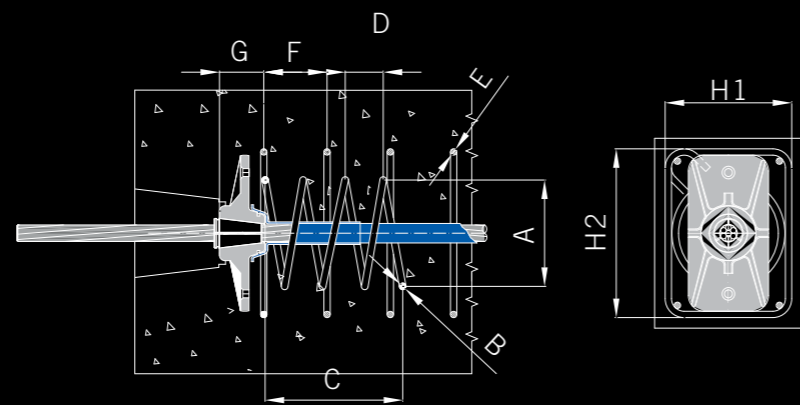

	SPIRRAL					ADDITIONAL REBAR					
	A [mm]	B [mm]	C [mm]	D [mm]	N. spire	E [mm]	F [mm]	G [mm]	H ₁ [mm]	H ₂ [mm]	N. stirrups
35MPa	110	6	131	40	3	6	60	40	120	160	5
45MPa	110	6	131	40	3	6	60	40	120	160	5

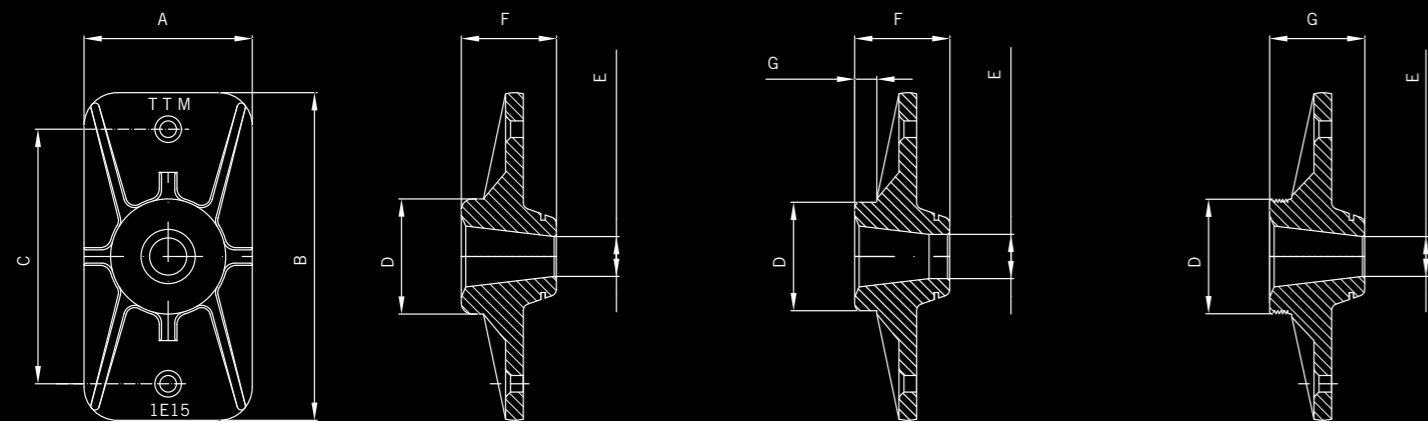

	A [mm]	B [mm]	C [mm]	D [mm]	E [mm]	F [mm]	G [mm]
1E15	76	148	115	52	18	43	-
1E15-F20	76	148	115	49	20	43	10
1E15-F	76	148	115	M51x1,5	18	43	-

SLAB / N ACTIVE ANCHORAGES

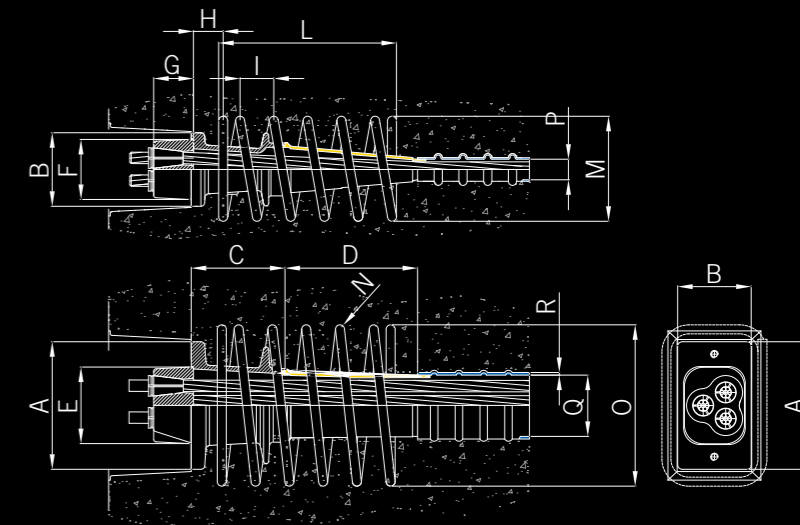

	Strands	A	B	C	D	E	F	G	H	I	L	M	N	O	P	Q	R
35MPa	3	170	95	125	200	102	80	53	41	45	237	150	12	245	25	76	2,5
	4	170	95	125	200	102	80	53	41	45	237	150	12	245	25	76	2,5
	5	188	100	125	185	120	80	53	40	45	259.5	170	12	265	20	90	2,5
45MPa	3	170	95	125	200	102	80	53	41	45	237	140	12	215	25	76	2,5
	4	170	95	125	200	102	80	53	41	45	237	140	12	215	25	76	2,5
	5	188	100	125	185	120	80	53	40	45	237	150	12	245	20	90	2,5

Dimensions in mm.

DIMENSIONS OF THE RECESS

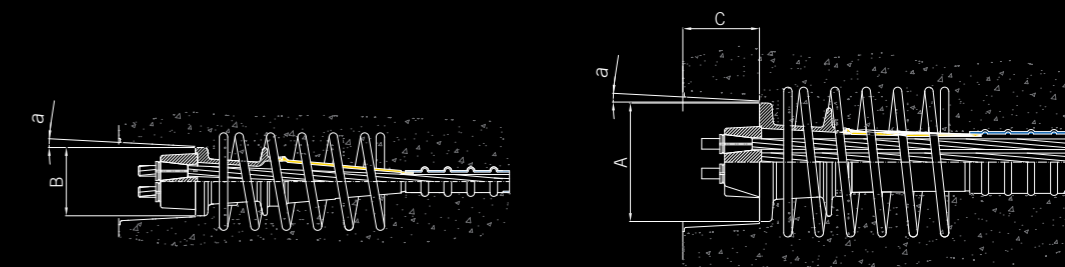

N. strands	A [mm]	B [mm]	C [mm]	a
3	200	110	120	5°
4	200	110	120	5°
5	200	110	120	5°

SLAB / ND PASSIVE ANCHORAGES

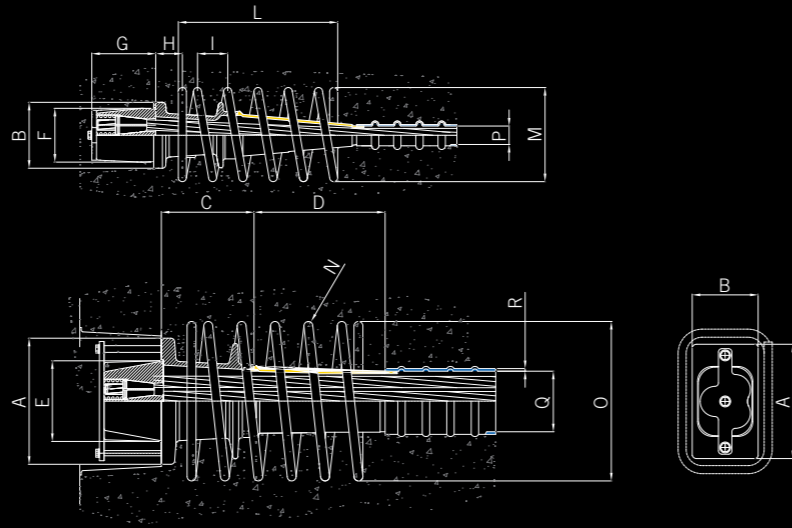

	Strands	A	B	C	D	E	F	G	H	I	L	M	N	O	P	Q	R
35MPa	3	170	95	125	200	102	80	88	41	45	237	150	12	245	25	76	2,5
	4	170	95	125	200	102	80	88	41	45	237	150	12	245	25	76	2,5
	5	188	100	125	185	120	80	88	40	45	259.5	170	12	265	20	90	2,5
45MPa	3	170	95	125	200	102	80	88	41	45	237	140	12	215	25	76	2,5
	4	170	95	125	200	102	80	88	41	45	237	140	12	215	25	76	2,5
	5	188	100	125	185	120	80	88	40	45	237	150	12	245	20	90	2,5

Dimensions in mm.

EQUIPMENT





QUALITY



TTM has developed a Quality Assurance plan in compliance with ISO 9001 and the ETAG013 Post-tension guideline. The application of strict process and product control procedures have allowed the company to obtain the CE marking from the competent Community Bodies.

A laboratory equipped with modern measurement and control equipment allows a constant and complete verification of the required characteristics. All the components of the structural system are identified at the moment of the acceptance and subjected to random checks.

The sampling plans are systematically applied and guarantee the verification and compliance with the requirements defined during the design phase.





Tension Technology Martin Srl.

Via Alberto da Giussano, 9 - 20011 Corbetta (MI) Italy
Tel. +39 02 97277811 - Fax +39 02 97277523

info@ttmsrl.it - www.ttmsrl.it